

ASI has supplied custom OEM pump assembly solutions for Proteomics-LCMS, Process Instrumentation, Pharmaceutical Manufacturing, Supercritical Fluid Chromatography, Preparative Chromatography, Biotech and SEC/GPC Systems.

Inquire about OEMs private labels

Option #1: mechanical pump assembly only

Option #2: pump + PCBA + hydraulics (transducer + purge valve)

Option #3: completed pump with enclosure

We will make a custom configuration per your specification.

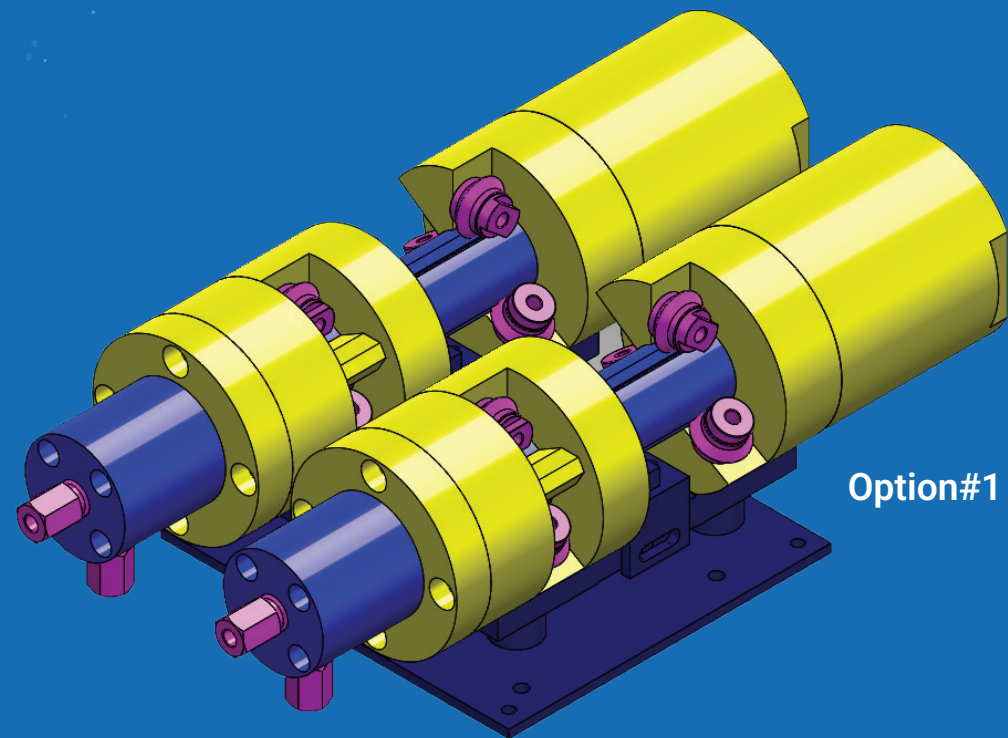

Option#1

Analytical Scientific Instruments US, Inc.
3023 Research Drive Richmond CA 94806 USA

www.hplc-asi.com

Phone: 510-669-2250

Email: info@hplc-asi.com

ASI *Analytical Scientific Instruments US*

Copyright © 2026 ASI - Analytical Scientific Instruments US, Inc.

Rev. 05_11_2026

578 NANO GRADIENT UPLC SYRINGE PUMP



Features:

- Repeatable gradients from 50 nL/min. to 5 μ L/min.
- Superior flow stability
- 20,000 psi maximum operating pressure
- Intuitive touch screen display for local control
- Windows based GUI for computer control (Modbus RTU, RS485)
- ASI nano check valve technology eliminates need for expensive rotary shear valves
NO MORE CONTAMINANTS FROM WORN ROTOR SEALS!
- Flow feedback for accurate and repeatable flow rate
- Optional solvent tray with solvent selection valves for up to 4 solvents
- Pressurized fill system speeds refill and prevents cavitation

ASI

Performance Data

ASI Model 578 Syringe Pumps outperformed competitors in head-to-head engineering trials. Applications requiring such high precision include: HPLC, LCMS, Sampling systems, Metering liquids and electrophoresis feed pumps.

Unmatched flow precision at high pressure make the ASI 578 Syringe Pump the top choice for design engineers.

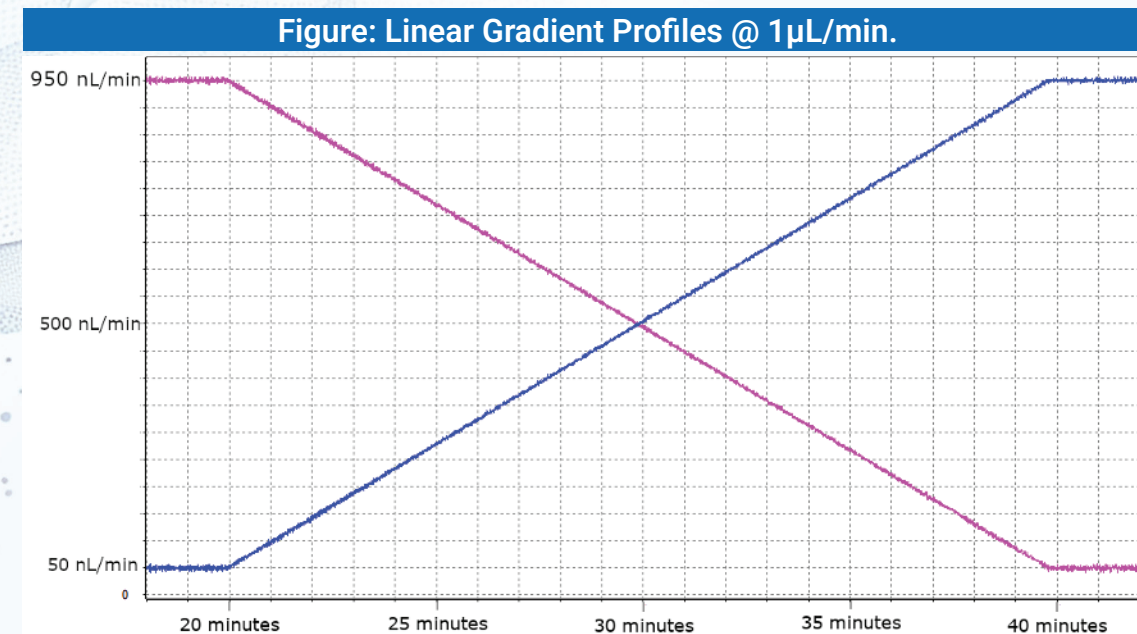

HPLC System:
ASI 578

HPLC Conditions:
MP: A = H₂O, B = MeOH
Flow Rate: 1 µL/min
Linear Gradient: 5% to 95% H₂O to MeOH
Sensirion Flow Meter

578 NANO Gradient UPLC Syringe Pump Specifications

Flow Range	50 nL/min. - 5 µL/min.
Max Pressure	20,000 PSI Max
Accuracy	±2% @ 500 nL/min. @ 4,000 PSI MeOH*
Precision	0.25%, 0.10 mL/min. - 1 µL/min. @ 4,000 PSI @ 20°C 5% to 95% Gradient
Flow Pulsation	.3% Δ P/P @ 4,000 PSI pressure
Dimension	9.0" W x 14.25" D x 7.5" H
Weight	20 lbs.
Power	AC 100 – 240 V 50/60 Hz, Fuse: 4A, 250 V
Motor	NEMA 17 triple stack step motor with motor drive & controller

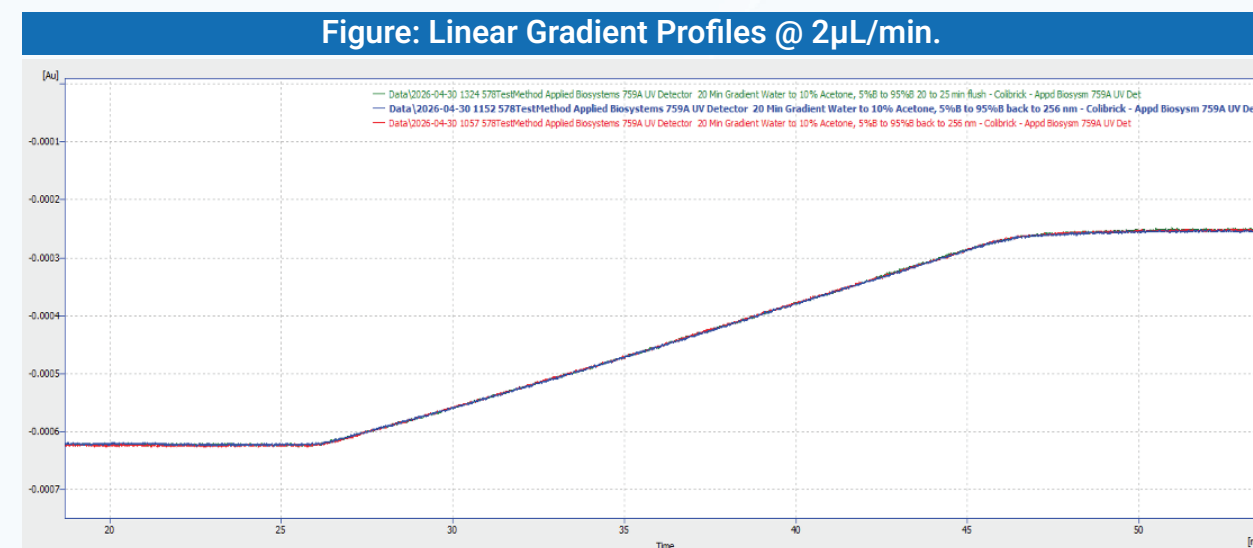

HPLC System:
ASI 578
UV 254 nm

HPLC Conditions:
2,000nL/min.
500psi backpressure
20 minute gradient
100 water Pump A, water w/ 10% acetone in Pump B

ASI